

## Design Features

- Standard sizes from 2" - 24".
- Available with RF or RTJ flanged (ASME B16.5), Buttweld (ASME B16.9) or grooved end connections.
- Standard thru bolt or grooved cover design.
- Custom modifications are available.
- May be installed in horizontal or vertical pipelines.
- All welders are qualified to ASME Section IX.
- Strainers designed to meet the requirements of ASME B31.1 and/or ASME B31.3.
- 304 SS perforated screens are standard.
- Drains connections are standard and are furnished with plug.
- Vents, differentials and special covers are optional.

### Parts list & Standard Materials (Flanged End)

Part	Carbon Steel	Stainless Steel <sup>1</sup>
Shell & Nozzles	A53 E/B / A106-B	A312
Reinforcement Pads <sup>2</sup>	A516-70	A240
Flanges	A105	A182
Coupling/threadolets:	A105	A182
Plug	A105	A182
Screen Retainer Ring	A36	A240
Screen <sup>3</sup>	304 SS	304 SS
Gasket <sup>3</sup>	304 SS Spiral Wound	304 SS Spiral Wound
Stud	A193-B7	A193-B8-1
Nut	A194-2H	A194-8

**Notes:** <sup>1</sup> Recommended Spares.

### Parts list & Standard Materials (Grooved End)

Part	Stainless Steel
Shell & Nozzles	A312-304
Flanges	A36 Zinc Plated
Plug	B584 Brass
Cover	Sizes 2 1/2" - 5" & 12": Ductile Iron Sizes 6" - 10": 304 SS
Screen <sup>1</sup>	304 SS
Gasket <sup>1</sup>	EPDM
Bolts	B633
Nuts	B633

**Notes:** <sup>1</sup> Recommended Spares.

## Upper Pressure Limits (non-shock) and Lower Temperature Limits (unless otherwise specified)

Class	Body Material	Size Range in. (mm)	Maximum Design Pressure psig (Bars) <sup>1</sup>	Low Temperature Limit - M.D.M.T. - °F (°C)
YI25FSBW	Carbon Steel	2" - 12" (50mm - 300mm)	200 (13.79) <sup>2</sup>	-20 (-28.9)
		14" - 24" (350mm - 600mm)	150 (10.34) <sup>2</sup>	-20 (-28.9)
YI25GSS4GW	304 SS	2 1/2" - 12" (65mm - 300mm)	200 (13.79) <sup>2</sup>	-20 (-28.9)
YI25FSS4BW / YI25FSS6BW	304 / 316 SS	2" - 12" (50mm - 300mm)	200 (13.79) <sup>2</sup>	-20 (-28.9)
		14" - 24" (350mm - 600mm)	150 (10.34) <sup>2</sup>	-20 (-28.9)
YI25FSS4LBW / YI25FSS6LBW	304L / 316L SS	2" - 12" (50mm - 300mm)	200 (13.79) <sup>2</sup>	-20 (-28.9)
		14" - 24" (350mm - 600mm)	150 (10.34) <sup>2</sup>	-20 (-28.9)
YI50FSBW	Carbon Steel	2" - 12" (50mm - 300mm)	285 (19.65) <sup>3</sup>	-20 (-28.9)
YI50FSS4BW / YI50FSS6BW	304 / 316 SS	2" - 12" (50mm - 300mm)	275 (18.96) <sup>3</sup>	-20 (-28.9)
YI50FSS4LBW / YI50FSS6LBW	304L / 316L SS	2" - 12" (50mm - 300mm)	230 (15.86) <sup>3</sup>	-20 (-28.9)

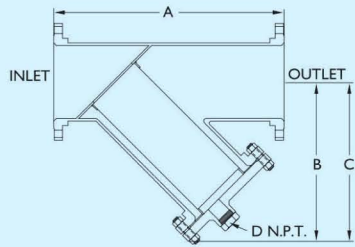

**YI50F**

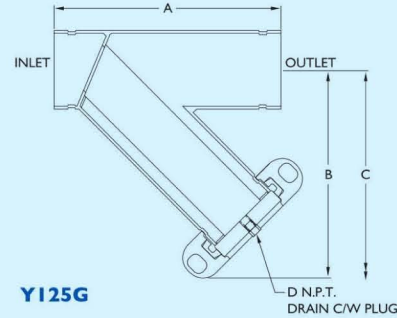

**YI25G**

## Standard Screens

Flanged End		Grooved End	
Size Range	Opening	Size range	Opening
2" - 8" (50mm - 200mm)	0.125 in. (3.2mm)	2.5" - 5" (65mm - 125mm)	0.063 in. (1.5mm)
10" - 12" (250mm - 300mm)	0.125 in. (3.2mm)	6" - 8" (150mm - 200mm)	0.125 in. (3.2mm)
14" - 24" (350mm - 600mm)	0.188 in. (4.8mm)	10" - 12" (250mm - 300mm)	0.188 in. (4.8mm)

## Dimensional Data

Size in. (mm)	A in. (mm)		B in. (mm)		C in. (mm)		D in. (mm)		Weight Lb. (kg)		Unit	
	Flanged	Grooved	Flanged	Grooved	Flanged	Grooved	Flanged	Grooved	Flanged	Grooved	Flanged	Grooved
2" 50	10.81 275	-	8.25 210	-	13.25 337	-	1/2 15	-	5 2	-	28 13	-
2 1/2" 65	13.38 340	9.5 241	10.25 260	8.81 224	16.44 418	14.06 357	1 25	1/2 15	9 4	1 0.45	81 37	21 10
3" 80	13.38 340	9.63 244	10.25 260	9.25 235	16.44 418	14.75 375	1 25	1/2 15	9 4	1.2 0.54	81 37	26 12
4" 100	14.75 375	11.63 295	10.50 267	11.25 286	16.75 425	18.50 470	1 1/2 40	1/2 15	17 8	2.5 1.13	85 39	33 15
5" 125	17.25 438	15.13 384	12.50 318	13.25 337	20.00 508	21.00 533	1 1/2 40	1/2 15	20 9	4.6 2.08	110 50	46 21
6" 150	22.00 559	18.00 457	14.00 356	15.81 402	22.44 570	25.75 654	2 50	3/4 20	26 12	1.6 0.72	145 66	70 32
8" 200	24.00 610	21.13 537	17.75 451	19.63 499	28.44 722	32.31 821	2 50	3/4 20	45 20	3.1 6	256 116	91 41
10" 250	31.50 800	25.50 648	22.00 559	24.69 627	35.25 895	41.00 1041	2 50	3/4 20	70 32	4.6 2	380 172	134 61
12" 300	32.75 832	29.38 746	25.00 635	27.88 708	40.00 1016	47.00 1194	2 50	3/4 20	110 50	36 16	700 317	225 102
14" 350	39.75 1010	-	27.00 686	-	43.25 1099	-	2 50	-	140 63	-	750 340	-
16" 400	45.25 1149	-	30.88 784	-	49.50 1257	-	2 50	-	180 82	-	905 410	-
18" 450	48.50 1232	-	33.88 861	-	54.25 1378	-	2 50	-	220 100	-	1125 510	-
20" 500	53.75 1365	-	39.00 991	-	62.50 1588	-	2 50	-	285 129	-	1415 641	-
24" 600	64.00 1626	-	44.00 1118	-	70.50 1791	-	2 50	-	430 195	-	1825 827	-

**Notes:** 1. Dimensions shown are subject to change.